

## TPS65130EVM-063 User's Guide

---



---

This user's guide describes the characteristics, operation, and use of the TPS65130EVM evaluation module (EVM). This EVM contains Texas Instruments TPS65130 positive and negative output supply IC. This user's guide includes EVM specifications, recommended test setup, test results, bill of materials (BOM), and a schematic diagram.

### Contents

1	Introduction .....	1
2	Input/Output Connector Descriptions .....	2
3	Board Layout .....	4
4	Bill of Materials and Schematic .....	7

### List of Figures

1	TPS65130 VPOS Efficiency Using the Wuerth 744031004, 4.7- $\mu$ H Inductor .....	3
2	TPS65130 VNEG Efficiency Using Wuerth 744031004, 4.7- $\mu$ H Inductor .....	3
3	Top Assembly Layer .....	4
4	Top Layer .....	5
5	Bottom Layer .....	6
6	TPA65130EVM-063 Schematic .....	8

### List of Tables

1	Typical Performance Specification Summary .....	2
2	HPA063 Bill of Materials .....	7

## 1 Introduction

The Texas Instruments TPS65130EVM evaluation module uses a TPS65130 multichannel output IC to provide both a positive and negative power rail. The goal of the EVM is to facilitate evaluation of the TPS65130.

## 1.1 Performance Specification Summary

Table 1 provides a summary of the TPS65130EVM performance specifications. All specifications are given for an ambient temperature of 25°C.

**Table 1. Typical Performance Specification Summary**

	CONDITION	VOLTAGE RANGE (V)			CURRENT RANGE (mA)		
		MIN	TYPE	MAX	MIN	TYP	MAX
VIN		2.7	3.3	5.5			2000
VPOS	$V_I = 3.3\text{ V}$	7.76	8	8.24			250
	$V_I = 5\text{ V}$						400
VNEG	$V_I = 3.3\text{ V}$	-5.15	-5	-4.85			190
	$V_I = 5\text{ V}$						260

## 1.2 Modifications

To aid user customization of the EVM, the board was designed with devices having 0603 or larger footprints. A real implementation would likely occupy less total board space.

Changing components can improve or degrade EVM performance. For example, using inductors with larger dc resistances lowers efficiency of the solution. Resistors R10 and R11 are for test purposes only. They can be replaced by a 51.1 - 100 ohm resistor and used to measure the loop gain with a loop gain analyzer. They are not required in a real application.

## 2 Input/Output Connector Descriptions

**J1–VIN** This is the positive connection to the input power supply. The leads to the input supply should be twisted and kept as short as possible.

**J2–GND** This is the return connection to the input power supply.

**J3–VPOS** This is the positive output of the device.

**J4–GND** This is the return connection for the load on the positive converter of the device.

**J5–VNEG** This is the negative output of the device.

**J6–GND** This is the return connection for the load on the negative converter of the device.

**JP1–ENP** This is the enable pin for the positive converter (VPOS). Placing a jumper across pins 2–3 of JP1 shorts the enable pin to GND, thereby disabling the device. Placing a jumper across pins 1–2 of JP1 connects the enable pin to  $V_{in}$  and enables the device.

**JP2–PSP** This is the control pin for the power-save mode of the positive converter. Placing a jumper across pins 2–3 of JP2 shorts the pin to GND, thereby disabling the power-save mode. Placing a jumper across pins 1–2 of JP2 connects the pin to  $V_I$ , thereby enabling the power-save mode.

**JP3–ENN** This is the enable pin for the negative converter (VNEG). Placing a jumper across pins 2–3 of JP3 shorts the enable pin to GND, thereby disabling the device. Placing a jumper across pins 1–2 of JP3 connects the enable pin to  $V_{in}$  and enables the device.

**JP4–PSN** This is the control pin for the power-save mode of the negative converter. Placing a jumper across pins 2–3 of JP4 shorts the pin to GND, thereby disabling the power-save mode. Placing a jumper across pins 1–2 of JP4 connects the pin to  $V_I$ , thereby enabling the power-save mode.

### 2.1 Test Setup

The absolute maximum input voltage is 6 V. The TPS65130 is designed to operate with a maximum input voltage of 5.5 V. Connect a power supply set between 2.7 V and 5.5 V output voltage and current limit set to at least 3 A. Short pins 1–2 on jumpers JP1 and JP2 to enable both rails.

## 2.2 Test Results

Below are the efficiency results using this EVM:

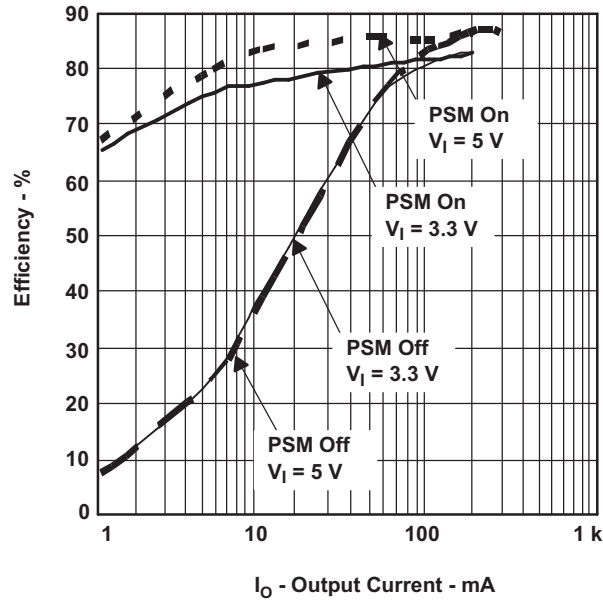

Figure 1. TPS65130 VPOS Efficiency Using the Wuerth 744031004, 4.7- $\mu$ H Inductor

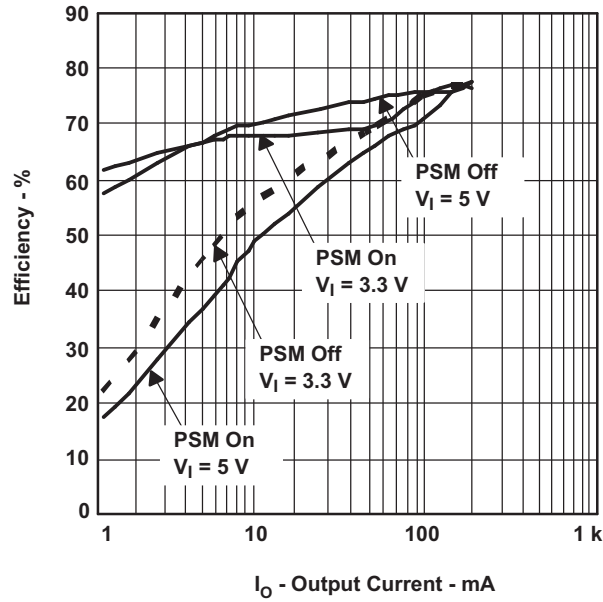

Figure 2. TPS65130 VNEG Efficiency Using Wuerth 744031004, 4.7- $\mu$ H Inductor

### 3 Board Layout

Board layout is critical for all switch mode power supplies. [Figure 3](#), [Figure 4](#), and [Figure 5](#) show the board layout for the HPA063 PWB. The switching nodes with high-frequency noise are isolated from the noise-sensitive feedback circuitry, and careful attention has been given to the routing of high-frequency current loops. See the data sheet for more specific layout guidelines.

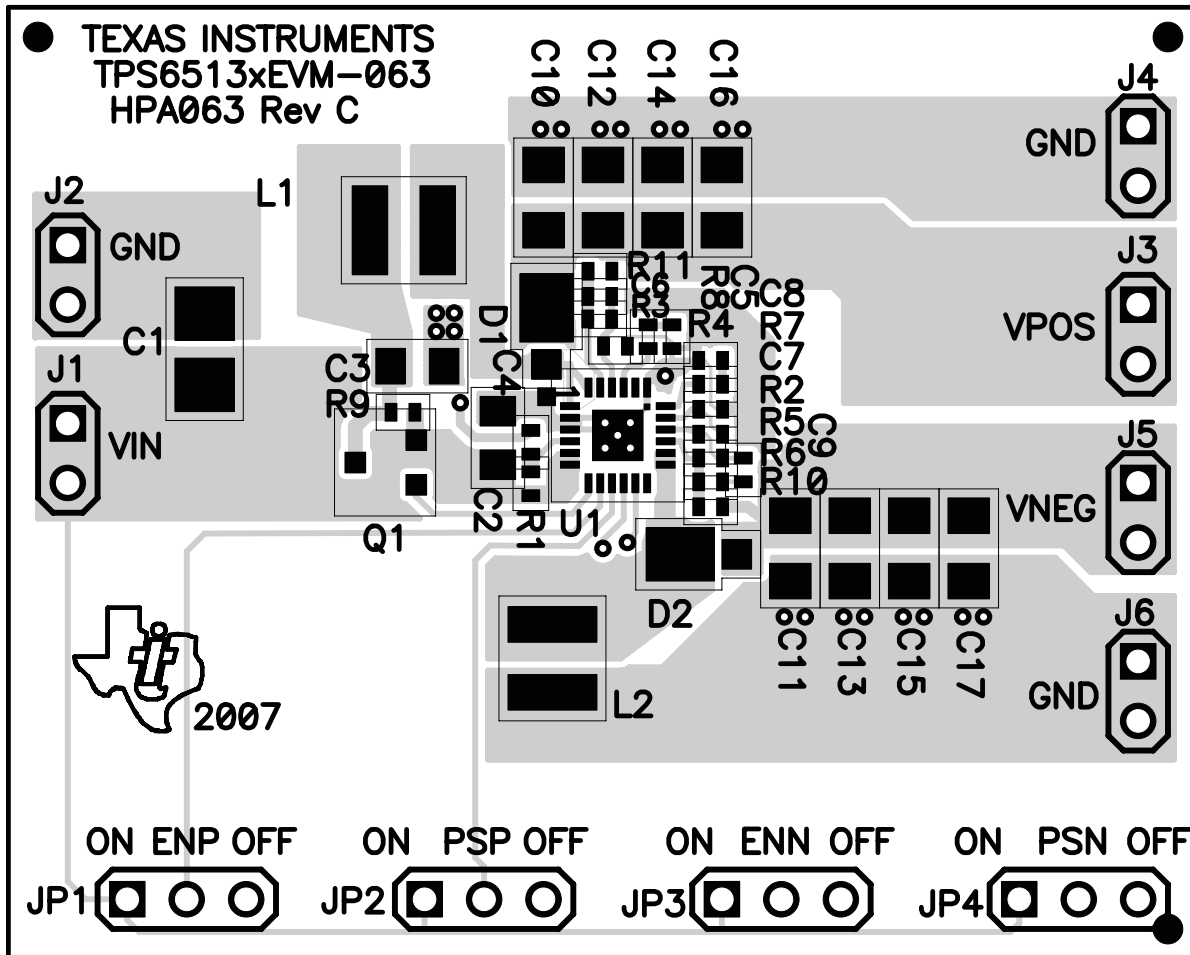

Figure 3. Top Assembly Layer



Figure 4. Top Layer



Figure 5. Bottom Layer

## 4 Bill of Materials and Schematic

### 4.1 Bill of Materials

**Table 2. HPA063 Bill of Materials**

COUNT	Ref Des	Value	DESCRIPTION	SIZE	Part Number	MFR
0	C1	Open	Capacitor, multi-pattern, SM 805 to 1210			
8	C10 - C17	4.7uF	Capacitor, Ceramic, 25V, X7R, 10%	1206	C3216X7R1E475KT	TDK
2	C2, C3	4.7uF	Capacitor, Ceramic, 6.3V, X5R, 10%	0805	C2012X5R0J475KT	TDK
1	C4	0.1uF	Capacitor, 10V, X5R, 10%	0402	C1005X5R1A104K	TDK
2	C5, C8	0.01uF	Capacitor, 16V, X7R, 10%	0402	C1005X7R1C103K	TDK
1	C6	6.8pF	Capacitor, 50V, C0G, 5%	0402	C1005C0G1H6R8D	TDK
1	C7	0.22uF	Capacitor, 6.3V, X5R, 10%	0402	C1005X5R0J224K	TDK
1	C9	12pF	Capacitor, 50V, C0G, 5%	0402	C1005C0G1H120J	TDK
2	D1, D2		Diode, Schottky, 1A, 20V	457-04	MBRM120	On Semi
6	J1 - J6		Header, 2 pin, 100mil spacing, (36-pin strip)	0.100 x 2	PTC36SAAN	Sullins
4	JP1 - JP4		Header, 3 pin, 100mil spacing, (36-pin strip)	0.100 x 3	PTC36SAAN	Sullins
2	L1, L2	4.7uH	Inductor, SMT, 0.9A, 85milliohms	0.150 X 0.150	744031004	WE
1	Q1		MOSFET,P-ch, -12 V, 4 A, 51 milliohm	SOT23	Si2323DS	Vishay
1	R1	100	Resistor, Chip, 1/16W, 1%	0402	Std	Std
1	R2	162k	Resistor, Chip, 1/16W, 1%	0402	Std	Std
1	R3	909k	Resistor, Chip, 1/16W, 1%	0402	Std	Std
1	R4	162k	Resistor, Chip, 1/16W, 1%	0402	Std	Std
1	R5	665k	Resistor, Chip, 1/16W, 1%	0402	Std	Std
1	R6	10k	Resistor, Chip, 1/16W, 1%	0402	Std	Std
3	R7, R10, R11	0	Resistor, Chip, 1/16W, 5%	0402	Std	Std
1	R8	1.0k	Resistor, Chip, 1/16W, 1%	0402	Std	Std
0	R9	Open	Resistor, Chip, 1/16W, 1%	0402		
1	U1		IC, Positive and Negative Output DC-DC Converter	QFN24	TPS65130RGE	TI
1	--		PCB, 2 In x 1.6 In x 0.062 In		HPA063	Any
4	--		Shunt, 100 mil, Black	0.100	929950-00	3M

## 4.2 Schematic

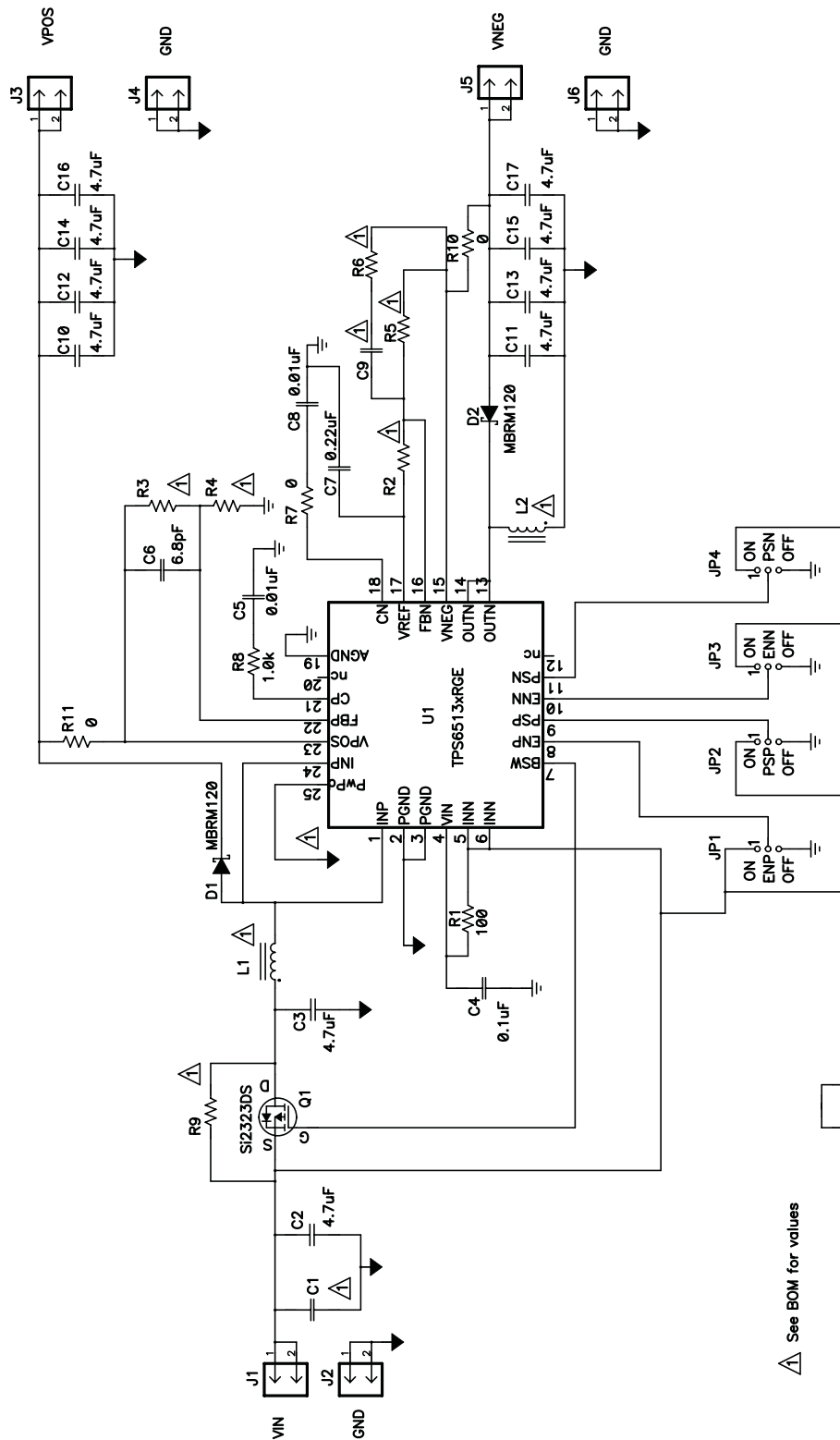

Figure 6. TPA65130EVM-063 Schematic



### **Related Documentation from Texas Instruments**

To obtain a copy of any of the following TI document, call the Texas Instruments Literature Response Center at (800) 477-8924 or the Product Information Center (PIC) at (972) 644-5580. When ordering, identify this booklet by its title and literature number. Updated documents can also be obtained through our website at [www.ti.com](http://www.ti.com)

**Data Sheets:**

TPS65130

**Literature Number:**

[SLVS493](#)

## EVALUATION BOARD/KIT IMPORTANT NOTICE

Texas Instruments (TI) provides the enclosed product(s) under the following conditions:

This evaluation board/kit is intended for use for **ENGINEERING DEVELOPMENT, DEMONSTRATION, OR EVALUATION PURPOSES ONLY** and is not considered by TI to be a finished end-product fit for general consumer use. Persons handling the product(s) must have electronics training and observe good engineering practice standards. As such, the goods being provided are not intended to be complete in terms of required design-, marketing-, and/or manufacturing-related protective considerations, including product safety and environmental measures typically found in end products that incorporate such semiconductor components or circuit boards. This evaluation board/kit does not fall within the scope of the European Union directives regarding electromagnetic compatibility, restricted substances (RoHS), recycling (WEEE), FCC, CE or UL, and therefore may not meet the technical requirements of these directives or other related directives.

Should this evaluation board/kit not meet the specifications indicated in the User's Guide, the board/kit may be returned within 30 days from the date of delivery for a full refund. **THE FOREGOING WARRANTY IS THE EXCLUSIVE WARRANTY MADE BY SELLER TO BUYER AND IS IN LIEU OF ALL OTHER WARRANTIES, EXPRESSED, IMPLIED, OR STATUTORY, INCLUDING ANY WARRANTY OF MERCHANTABILITY OR FITNESS FOR ANY PARTICULAR PURPOSE.**

The user assumes all responsibility and liability for proper and safe handling of the goods. Further, the user indemnifies TI from all claims arising from the handling or use of the goods. Due to the open construction of the product, it is the user's responsibility to take any and all appropriate precautions with regard to electrostatic discharge.

**EXCEPT TO THE EXTENT OF THE INDEMNITY SET FORTH ABOVE, NEITHER PARTY SHALL BE LIABLE TO THE OTHER FOR ANY INDIRECT, SPECIAL, INCIDENTAL, OR CONSEQUENTIAL DAMAGES.**

TI currently deals with a variety of customers for products, and therefore our arrangement with the user **is not exclusive.**

TI assumes **no liability for applications assistance, customer product design, software performance, or infringement of patents or services described herein.**

Please read the User's Guide and, specifically, the Warnings and Restrictions notice in the User's Guide prior to handling the product. This notice contains important safety information about temperatures and voltages. For additional information on TI's environmental and/or safety programs, please contact the TI application engineer or visit [www.ti.com/esh](http://www.ti.com/esh).

No license is granted under any patent right or other intellectual property right of TI covering or relating to any machine, process, or combination in which such TI products or services might be or are used.

### FCC Warning

This evaluation board/kit is intended for use for **ENGINEERING DEVELOPMENT, DEMONSTRATION, OR EVALUATION PURPOSES ONLY** and is not considered by TI to be a finished end-product fit for general consumer use. It generates, uses, and can radiate radio frequency energy and has not been tested for compliance with the limits of computing devices pursuant to part 15 of FCC rules, which are designed to provide reasonable protection against radio frequency interference. Operation of this equipment in other environments may cause interference with radio communications, in which case the user at his own expense will be required to take whatever measures may be required to correct this interference.

Mailing Address: Texas Instruments, Post Office Box 655303, Dallas, Texas 75265  
Copyright © 2007, Texas Instruments Incorporated

### EVM WARNINGS AND RESTRICTIONS

It is important to operate this EVM within the input voltage range of 2.7 V to 5.5 V and the output voltage range of -15 V to 15 V.

Exceeding the specified input range may cause unexpected operation and/or irreversible damage to the EVM. If there are questions concerning the input range, please contact a TI field representative prior to connecting the input power.

Applying loads outside of the specified output range may result in unintended operation and/or possible permanent damage to the EVM. Please consult the EVM User's Guide prior to connecting any load to the EVM output. If there is uncertainty as to the load specification, please contact a TI field representative.

During normal operation, some circuit components may have case temperatures greater than 125°C. The EVM is designed to operate properly with certain components above 125°C as long as the input and output ranges are maintained. These components include but are not limited to linear regulators, switching transistors, pass transistors, and current sense resistors. These types of devices can be identified using the EVM schematic located in the EVM User's Guide. When placing measurement probes near these devices during operation, please be aware that these devices may be very warm to the touch.

Mailing Address: Texas Instruments, Post Office Box 655303, Dallas, Texas 75265  
Copyright © 2007, Texas Instruments Incorporated

## IMPORTANT NOTICE

Texas Instruments Incorporated and its subsidiaries (TI) reserve the right to make corrections, modifications, enhancements, improvements, and other changes to its products and services at any time and to discontinue any product or service without notice. Customers should obtain the latest relevant information before placing orders and should verify that such information is current and complete. All products are sold subject to TI's terms and conditions of sale supplied at the time of order acknowledgment.

TI warrants performance of its hardware products to the specifications applicable at the time of sale in accordance with TI's standard warranty. Testing and other quality control techniques are used to the extent TI deems necessary to support this warranty. Except where mandated by government requirements, testing of all parameters of each product is not necessarily performed.

TI assumes no liability for applications assistance or customer product design. Customers are responsible for their products and applications using TI components. To minimize the risks associated with customer products and applications, customers should provide adequate design and operating safeguards.

TI does not warrant or represent that any license, either express or implied, is granted under any TI patent right, copyright, mask work right, or other TI intellectual property right relating to any combination, machine, or process in which TI products or services are used. Information published by TI regarding third-party products or services does not constitute a license from TI to use such products or services or a warranty or endorsement thereof. Use of such information may require a license from a third party under the patents or other intellectual property of the third party, or a license from TI under the patents or other intellectual property of TI.

Reproduction of information in TI data books or data sheets is permissible only if reproduction is without alteration and is accompanied by all associated warranties, conditions, limitations, and notices. Reproduction of this information with alteration is an unfair and deceptive business practice. TI is not responsible or liable for such altered documentation.

Resale of TI products or services with statements different from or beyond the parameters stated by TI for that product or service voids all express and any implied warranties for the associated TI product or service and is an unfair and deceptive business practice. TI is not responsible or liable for any such statements.

TI products are not authorized for use in safety-critical applications (such as life support) where a failure of the TI product would reasonably be expected to cause severe personal injury or death, unless officers of the parties have executed an agreement specifically governing such use. Buyers represent that they have all necessary expertise in the safety and regulatory ramifications of their applications, and acknowledge and agree that they are solely responsible for all legal, regulatory and safety-related requirements concerning their products and any use of TI products in such safety-critical applications, notwithstanding any applications-related information or support that may be provided by TI. Further, Buyers must fully indemnify TI and its representatives against any damages arising out of the use of TI products in such safety-critical applications.

TI products are neither designed nor intended for use in military/aerospace applications or environments unless the TI products are specifically designated by TI as military-grade or "enhanced plastic." Only products designated by TI as military-grade meet military specifications. Buyers acknowledge and agree that any such use of TI products which TI has not designated as military-grade is solely at the Buyer's risk, and that they are solely responsible for compliance with all legal and regulatory requirements in connection with such use.

TI products are neither designed nor intended for use in automotive applications or environments unless the specific TI products are designated by TI as compliant with ISO/TS 16949 requirements. Buyers acknowledge and agree that, if they use any non-designated products in automotive applications, TI will not be responsible for any failure to meet such requirements.

Following are URLs where you can obtain information on other Texas Instruments products and application solutions:

<b>Products</b>		<b>Applications</b>	
Amplifiers	<a href="http://amplifier.ti.com">amplifier.ti.com</a>	Audio	<a href="http://www.ti.com/audio">www.ti.com/audio</a>
Data Converters	<a href="http://dataconverter.ti.com">dataconverter.ti.com</a>	Automotive	<a href="http://www.ti.com/automotive">www.ti.com/automotive</a>
DSP	<a href="http://dsp.ti.com">dsp.ti.com</a>	Broadband	<a href="http://www.ti.com/broadband">www.ti.com/broadband</a>
Interface	<a href="http://interface.ti.com">interface.ti.com</a>	Digital Control	<a href="http://www.ti.com/digitalcontrol">www.ti.com/digitalcontrol</a>
Logic	<a href="http://logic.ti.com">logic.ti.com</a>	Military	<a href="http://www.ti.com/military">www.ti.com/military</a>
Power Mgmt	<a href="http://power.ti.com">power.ti.com</a>	Optical Networking	<a href="http://www.ti.com/opticalnetwork">www.ti.com/opticalnetwork</a>
Microcontrollers	<a href="http://microcontroller.ti.com">microcontroller.ti.com</a>	Security	<a href="http://www.ti.com/security">www.ti.com/security</a>
RFID	<a href="http://www.ti-rfid.com">www.ti-rfid.com</a>	Telephony	<a href="http://www.ti.com/telephony">www.ti.com/telephony</a>
Low Power Wireless	<a href="http://www.ti.com/lpw">www.ti.com/lpw</a>	Video & Imaging	<a href="http://www.ti.com/video">www.ti.com/video</a>
		Wireless	<a href="http://www.ti.com/wireless">www.ti.com/wireless</a>

Mailing Address: Texas Instruments, Post Office Box 655303, Dallas, Texas 75265  
Copyright © 2007, Texas Instruments Incorporated